

PRODUCT INFORMATION

ROTARY POLISHER PRP 377

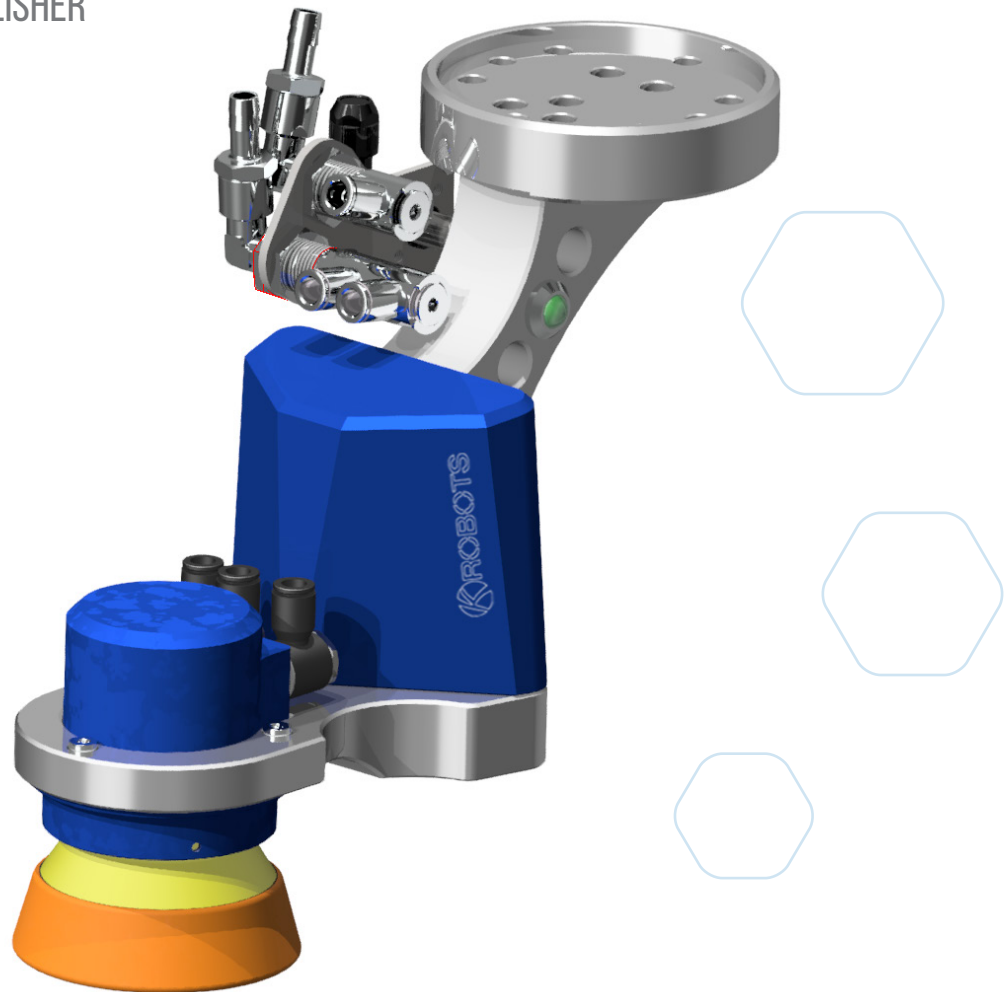

EFFICIENT. FLEXIBLE. COMPLIANT.
PNEUMATIC ROTARY POLISHER



PRP 377 - OPTIMAL POLISHER FOR ROBOT USE

The work steps such as grinding and polishing are still among the most labor- and personnel-intensive areas within surface processing, be it in the automotive, metal, plastics or wood processing industries. The automated grinding process achieves an evenly ground surface structure.

The PRP 377 polishing tool is designed for 24/7 continuous use on the robot. For an optimal polishing result, the speed and the contact force can be adjusted individually.

Large compliance of 16 mm (± 8) in the axial direction allows for simplified robot programming.

With various attachments and interface pads, 75 mm polishing agents from any manufacturer can be used.

Using various adapters and flanges, PRP 377 is compatible with all common cobot and industrial robot models from manufacturers: Yaskawa, Fanuc, ABB, Kuka, Stäubli, Hanwha, UR, Omron, Nachi...

COMPENSATION
PATH Z
16 MM

SPEED MAX.
3000 1/MIN

WEIGHT
3,9 KG

BACKING PAD
 \varnothing 75 MM

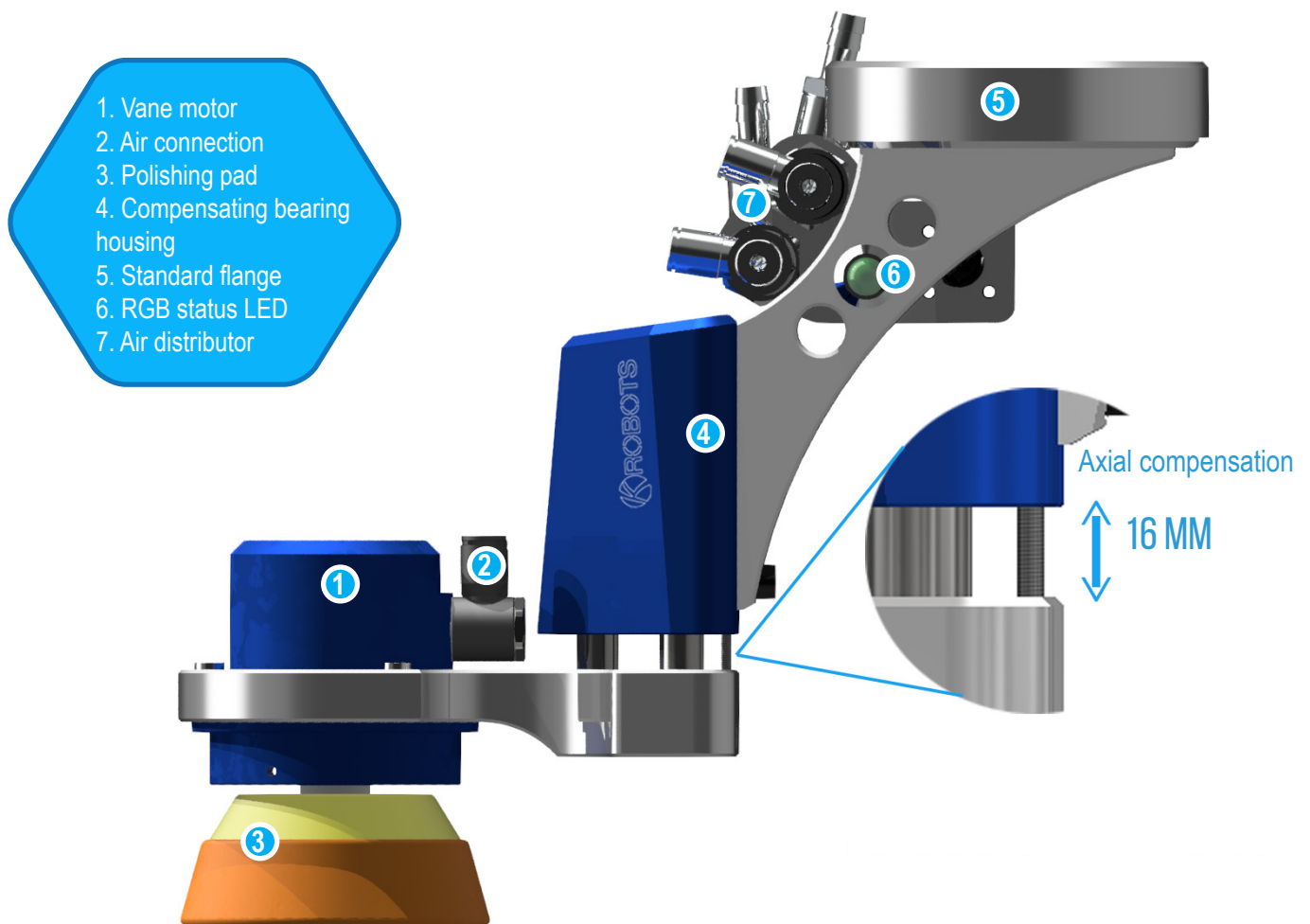

FUNCTIONAL DESCRIPTION

The polisher is driven by a powerful vane motor. This is powered by filtered and oiled air. The motor is mounted in an axially flexible manner to compensate for tolerances on the workpiece surface and to ensure a constant contact force during the grinding or polishing process. The contact pressure can be controlled separately via an air connection so that a variable contact pressure can be achieved.

Integrated end position monitoring (optional) via inductive sensors can be used programmatically for various purposes, such as correction in the Z direction, wear compensation, etc.

Slim and compact design, stable aluminum housing and weight of less than 4 kilos, as well as modular design enables easy replacement of wearing parts for maximum system availability and minimized spare parts requirements.

DIMENSIONS AND TECHNICAL DATA

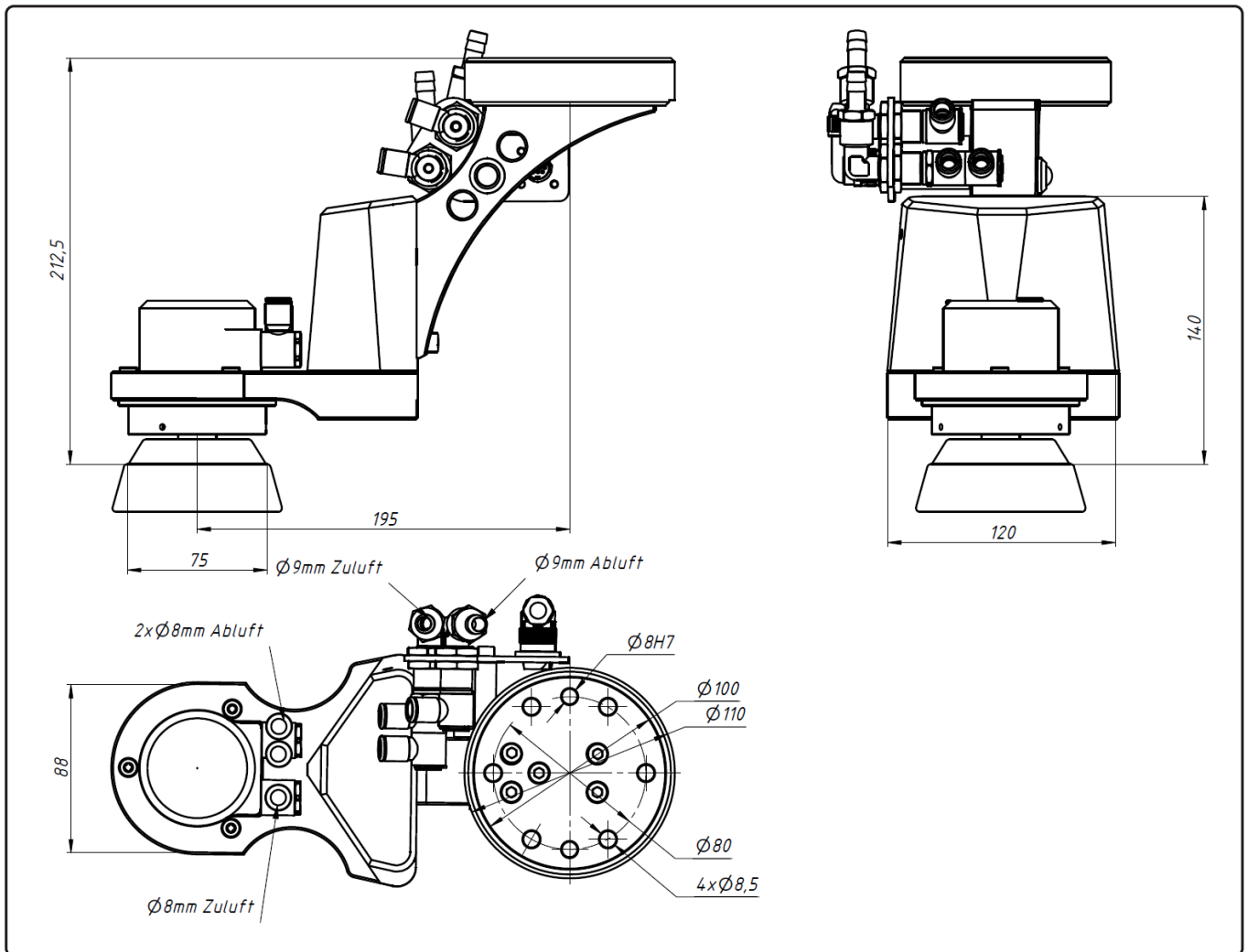

TECHNISCHE DATEN / TECHNICAL DATA:

Bezeichnung/Typ		Pneumatic Robot Polisher PRP-377
Article-Nr.		12002
Backing Pad D	[mm]	77 (Thread 1/4")
Compensation mechanism		with self-weight compensation springs
Compensation path Z (Max.)	[mm]	16
Recommended compensation path	[mm]	15
Min./Max. Extend compensating force	[N]	100
Min./Max. Compensating pressure	[bar]	3
Eccentric stroke	[mm]	0
Vibration	[m/s ²]	2,48
Engine Power	[W]	250
Idle speed	[1/min]	3000
Working Pressure	[bar]	6,8
Noise emission	[dB(A)]	78
Maximum air consumption	[l/min]	480
Engine air connection	[mm]	9
Air connection compensation	[mm]	6
Weight	[kg]	3,8
Min./max. Ambient temperature	[°C]	1 - 50
Dimensions B x T x H (without sanding disc)	[mm]	122 x 295 x 200
Standard flange ISO 9409-1	[mm]	6 x ø80 (Other dimensions possible)
LED-Status indicator (Optional)		24 V RGB LED, ø14 mm
Compensation path end position monitoring (Optional)		Upper/lower limit position, inductive proximity switch
Pneumatic Robot control PRC-2000 (Optional)		Contact force/speed control

TYPE CODE

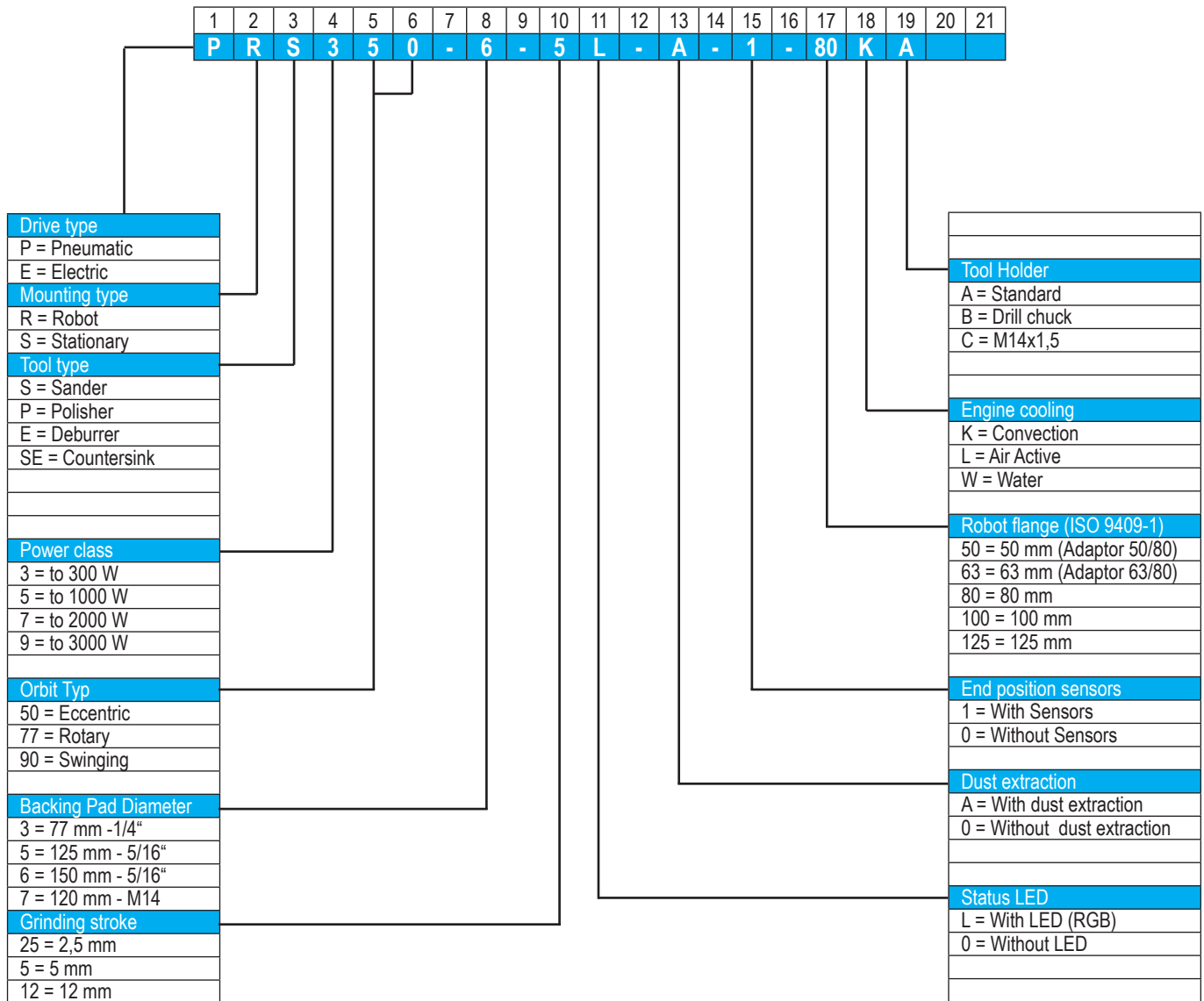

COMPENSATING FORCE

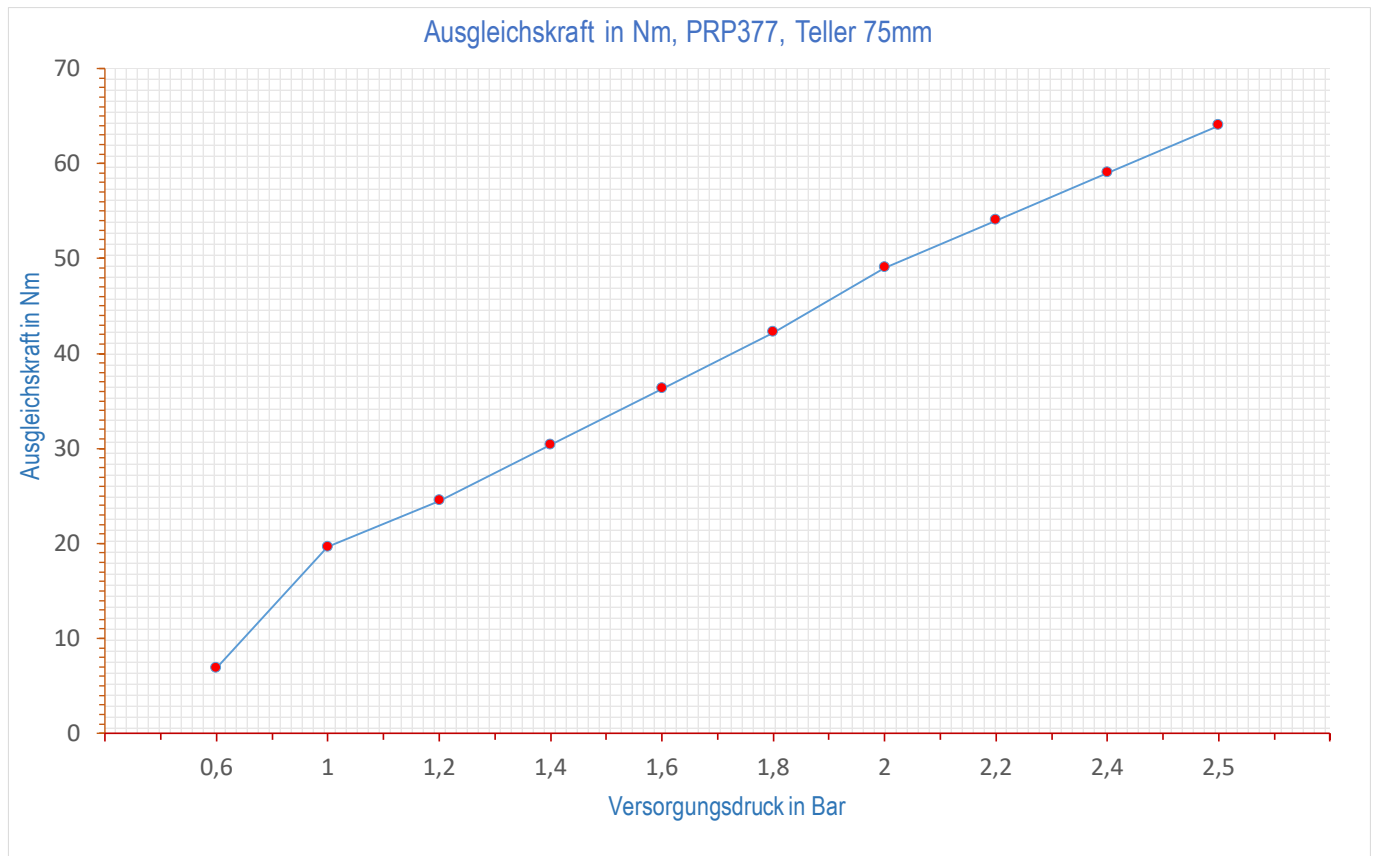

Notice

The compensating force can vary from product to product and should only be treated as a guide. The actual force characteristics depend on the installation position and the condition of the product. The compensation pressure should be selected depending on the material of the workpiece, the type of tool and the amount of material to be removed.

The specified compensating force only corresponds to the actual values when the product is mounted horizontally and the engine is switched off.



K-ROBOTS

Robert Bosch Str. 1

77871 Renchen

Mobil: +49 176 699 544 07

Mail. info@k-robots.de

www.k-robots.de

